

SPA MICROPROCESSOR COMBINED TACHO&SPEEDO/GAUGE
INSTALLATION AND OPERATING MANUAL

PAGE 2INSTRUMENT FEATURES

PAGE 3OPERATING INSTRUCTIONS

PAGE 3MENU SYSTEM

PAGE 9....INSTALLATION DIAGRAMS

PAGE 13....INSTALLATION NOTES

PAGE 14....SPECIFICATIONS

INSTRUMENT FEATURES

STEPPER MOTOR DRIVEN NEEDLE

QUARTZ MICRPROCESSOR ACCURACY

BUILT IN DIGITAL TACHOMETER

BUILT IN SPEEDOMETER/GAUGE*

TIMER FOR 0-60 ETC

STANDING QUARTER TIMER

INTERNAL 3 STAGE SHIFT LAMP

EXTERNAL SHIFT LAMPS (OPTIONAL)

BACKLIT SCALE AND DISPLAY

MAXIMUM RECALLS

SETTINGS AND MAXIMUMS STORED INDEFINITELY IN EEPROM MEMORY.

FULLY USER PROGRAMMABLE MENU SYSTEM FOR :-

TACHOMETER

SPEEDOMETER*

TRIP MILEOMETER (SELECTABLE)*

SHIFT LIGHTS

SCALE BACKLIGHT ON/OFF

BACKLIGHT BRIGHTNESS

'LIGHTS ON' WIRE*

GAUGE UNITS SELECTION*

GAUGE ALARM INDICATION*

*ACCORDING TO MODEL OPTION

OPERATING INSTRUCTIONS:-

When the SPA tachometer is first switched you will see SPA displayed on the LCD display, and you will see the needle drive back to the stop pin. After a few seconds the needle will drive forward to the zero mark. The LCD display will now read speed or gauge data according to model option and the tachometer will now register engine RPM and the digital display as RPM x1000. Pressing the red button after this will either recall any stored maximum speed and RPM on the tachometer, or on the speedo/tacho version, this can also be configured to recall and reset trip mileometer.

The SPA Microprocessor tachometer is factory set to standard parameters, but may be adjusted to your requirements using a menu system that will be explained further on. All settings and maximums are stored in EEPROM memory, which will store them for many years without any power needed.

As supplied the RPM shift points are set to 7200, 7600 and 8000 RPM, cylinders set to 4, and on speedo/tacho's tyre Circumference is set to 1.800 Metres, using 1 trigger point for use with the 1 trigger magnet that is supplied as standard. Also tacho/gauge types are setup for the standard SPA sensors that they are supplied with.

The speed and RPM on the LCD display is always updated every 0.4 Sec, but the maximum RPM, maximum speed and shift point detection's are always measured and stored at a much higher rate depending on the engine RPM and road speed (typically 40 times a second) for a fast and true response.

If the supply voltage to the instrument drops to below 8.00 Volts, a small battery symbol will display on the left of the LCD display indicating that battery volts are low. The tachometer will still function normally at this voltage, but if the voltage drops down below 8.00 volts, the instrument will reset itself.

MENU SYSTEM:-

To access the menu, hold down the red button and then switch on the instrument. On the display you will see "bon" on the LCD display, now release the button. If you now press the red button momentarily again you will see it increment to the next menu option, keep doing this to familiarise yourself with them. The sequence of displays and there meaning is shown below:-

bon = **backlight on** or, **b--** = **backlight off**.
bri = **brightness**, set brightness off backlight.
rtP = **reset Peak**, IE reset stored maximum RPM to zero.

Speedo version:-

St4 = routine for measuring **Standing** quarter time.
SSP = set **Start SP**eed for the acceleration timer.
FSP = set **Finish SP**eed for the acceleration timer.
ACC = routine for measuring **ACC**eleration time.

Pressure/Boost version:-

Uni = Set **Units** for pressure readout. **Psi, bAr, CM2**
ALA = Set **AL**arm point for low pressure (over pressure on boost version)
oFP = Zero **oF**ffset for **p**ressure

Temperature version:-

dEg = Set **dEg**rees for temperature readout.

tYP = Set the **tYPe** of temperature sensor used. **tEM**, **tHi**, **tLo**

ALA = Set **ALArm** point for high temperature

Volts version:-

ALA = Set **ALArm** point for low voltage

All models:-

CyL = set the number of engine **CyLinders** routine.

SF1 = set the RPM **ShiFt** point one (green led).

SF2 = set the RPM **ShiFt** point two (yellow led).

SF3 = set the RPM **ShiFt** point three (red led).

Fon = **Filter on** or, **F--** = **Filter off**.

Speedo version:-

tot = **total** distance recall recorded on odometer.

tr = set **tRigger** points routine.

CAL = set **CALibration** to tyre circumference routine.

rEA = set **REAdout** to KMH, MPH or RPM indicated by "KPH", "MPH" or neither on the bottom right of the LCD display.

ton = **trip** mileometer **on**, or **t--** = **trip** mileometer off.

All models:-

Eng = This routine is for engineering access only.

rEt = Exit the menu system and **rEt**urn to normal operation.

The display then scrolls back around to **bon**.

To activate any option or routine, press and hold down the red button, the display will change after 2 seconds.

A more detailed breakdown of each menu option is detailed on this and the following pages.

All versions:-

Bon (BACKLIGHT ON/OFF):- Press and hold down the red button, after 2 seconds the display changes to the desired option. Normally this is set to ON unless you need to reduce battery consumption.

bri = **brightness**, set brightness off backlight.

Press and hold down the red button, after 2 seconds the display indicates the current brightness level. To change the brightness, press the red button momentarily to increment it one at a time, or press and hold and the display will count up quickly. When the display reaches full brightness **064** it will scroll back round to **000** (dark). To exit the routine, release the button for more than 4 seconds and it will return to the menu, or switch off the instrument.

rtP(RESET PEAKS):- Press and hold down the red button, after 2 seconds the display shows --- . The stored maximums are now reset to zero. This should be done before any new maximums are to be stored.

Pressure/Boost version:-

Uni = Set **Units** for pressure readout for a standard SPA 16 bar sensor. **Psi**, **bAr**, **CM2** (Kg/Cm²)

Press and hold down the red button, after 2 seconds the display indicates the current selection. To change the option, press the red button momentarily to increment it one at a time. To exit the routine, release the button for more than 4 seconds and it will return to the menu, or switch off the instrument.

ALA = Set **ALArm** point for low pressure (over pressure on boost version)

Press and hold down the red button, after 2 seconds the display indicates the current selection. To change

the number, press the red button momentarily to increment it one at a time, or press and hold, and the display will count up quickly. When the display reaches full scale it will scroll back round to **000** (000 = alarm inactive). To exit the routine, release the button for more than 4 seconds and it will return to the menu, or switch off the instrument.

oFP = Zero **oF**ffset for **p**ressure, use this to make the gauge read zero when the pressure sensor at zero pressure.

Press and hold down the red button, after 2 seconds the display changes to **rEA**. Release the button and the display now shows the voltage being read from the sensor. Ensure that the sensor is at zero pressure, then press and hold the red button for 2 secs until the display changes to ---. Now wait until the display returns to **oFP**. To exit the routine, release the button for more than 4 seconds and it will return to the menu, or switch off the instrument.

Temperature version:-

dEg = Set **dE**grees for temperature readout.

Press and hold down the red button, after 2 seconds the display indicates the current selection. To change the option, press the red button momentarily to increment it one at a time. To exit the routine, release the button for more than 4 seconds and it will return to the menu, or switch off the instrument.

tYP = Set the **tYP**e of temperature sensor used. **tEM** = standard brass **tEM**perature sensor, **tHi** = thermocouple **High** adapter box used, **tLo** = thermocouple **Low** adapter box used.

Press and hold down the red button, after 2 seconds the display indicates the current selection. To change the option, press the red button momentarily to increment it one at a time. To exit the routine, release the button for more than 4 seconds and it will return to the menu, or switch off the instrument.

ALA = Set **AL**Arm point for high temperature

Press and hold down the red button, after 2 seconds the display indicates the current selection. To change the number, press the red button momentarily to increment it one at a time, or press and hold, and the display will count up quickly. When the display reaches full scale, it will scroll back round to **000** (000 = alarm inactive). To exit the routine, release the button for more than 4 seconds and it will return to the menu, or switch off the instrument.

Volts version:-

ALA = Set **AL**Arm point for low voltage

Press and hold down the red button, after 2 seconds the display indicates the current selection. To change the number, press the red button momentarily to increment it one at a time, or press and hold, and the display will count up quickly. When the display reaches full scale it will scroll back round to **000** (000 = alarm inactive). To exit the routine, release the button for more than 4 seconds and it will return to the menu, or switch off the instrument.

Speedo version:-

St4 (STANDING QUARTER TIME):- This routine is used to display the current stored standing quarter time, terminal speed, terminal RPM, and to measure and store new times. To access this routine, press and hold down the red button, after 2 seconds the display will show the currently stored acceleration time. Press the button again momentarily to display terminal speed, and RPM, and press again to return to the **St4** menu.

To start a new standing quarter measurement, press and hold the button to display the current standing quarter time, then press and hold down the red button, after 2 seconds the display changes "---", release the button and normal road speed and RPM (with shift lights) will be now be displayed. Accelerate the car and as soon as the wheels begin moving, standing quarter timer will start, and your road speed will be displayed along with the "REC" symbol on the top right of the display. When you have travelled for a

quarter of a mile, the "REC" symbol will go out, and your new standing quarter time will be displayed. To abort at any point in this routine, press the red button momentarily and the display will show the time from start (if any) to button press.

Press the button momentarily and you can view your terminal speed and RPM. Press again, and you will return to the **ST4** menu.

SSP (START SPEED):- Use this routine to enter the speed that you wish to start to measure the acceleration for. EG 0 for 0-60 MPH

Press and hold down the red button, after 2 seconds the display indicates the current acceleration speed the instrument is set to. To change the number, press the red button momentarily to increment it one at a time, or press and hold, and the display will count up quickly. When the display reaches **200** it will scroll back round to **000**. To exit the routine, release the button for more than 4 seconds and it will return to the menu, or switch off the instrument.

FSP (FINISH SPEED):- Use this routine to enter the speed that you wish to finish measuring the acceleration for. EG 60 for 0-60 MPH

Press and hold down the red button, after 2 seconds the display indicates the current acceleration speed the instrument is set to. To change the number, press the red button momentarily to increment it one at a time, or press and hold, and the display will count up quickly. When the display reaches **200** it will scroll back round to **001**. To exit the routine, release the button for more than 4 seconds and it will return to the menu, or switch off the instrument.

ACC (ACCELERATION TIME):- This routine is used to display the current stored acceleration time, and to measure and store new acceleration times. To access this routine, press and hold down the red button, after 2 seconds the display will show the currently stored acceleration time. To start a new acceleration measurement, press and hold down the red button, after 2 seconds the display changes to "---" indicating it is ready. Accelerate the car and as soon as the wheels begin moving (for 0-60) or when the start speed has been reached, the speedo will start the acceleration timer, and your road speed will be displayed along with the "REC" symbol on the top right of the display. When you reach the programmed speed, the "REC" symbol will go out, and your new acceleration time will be displayed. To return to the menu at any point in this routine, press the red button momentarily and the display will change back to "**ACC**".

All versions:-

CyL (SET CYLINDERS):- Press and hold down the red button, after 2 seconds the current cylinders will be displayed. To change the number, press the red button momentarily to increment it one at a time, or press and hold down and the display will count up quickly. When the display reaches 16 it will scroll back round to 1. For certain types of ignition systems, that is ones that have more than one ignition coil per engine, it will be necessary to set the cylinders to a different number than the engine has. If you are using a tachometer output from the ignition amplifier box, some systems (like the Ford coil less) give half the ignition pulses and so cylinders would be set to 2.

Also most motorcycles use an ignition coil per pair of cylinders, so a 4 cylinder engine would need to be set to 2 on the tachometer since it will only see half the number of ignition pulses.

SF1,2,3 (SET SHIFT RPM):- This routine is used to enter the shift points for the engine being used. When the engine RPM exceeds this shift point number, then the appropriate lamp will light. These are: -

SF1 - green led

SF2 - yellow led

SF3 - red led (very bright)

If you wish you can also drive external shift lamps.

(see installation notes for details)

Press and hold down the red button, after 2 seconds the current shift point will be displayed as x1000 RPM. To change the number, press the red button momentarily to count it up one hundred RPM at a time, or press and hold and the display will count up quickly. When the display shows 39.90 it will scroll back

round to 00.10 To exit the routine, release the button for more than 4 seconds and it will return to the menu, or switch off the instrument.

NOTE: In practice, you may find that when you look at your Maximum RPM recall, that you have over shot your highest shift point due human reaction time, so you may wish to decrease your shift point(s) to compensate for this and increase the efficiency of your gear shifting further. EG if you set the shift point to 7,900 but you Maximum RPM recall was 8,200 then set your shift point to 7,700 to compensate for your reaction time.

Fon(FILTER ON/OFF):- Press and hold down the red button, after 2 seconds the display changes to the desired option. Normally this is set to ON, but if you are using CDI ignition you may have to select it to OFF as the ignition pulses are very short.

Speedo version:-

tot (TOTAL DISTANCE RECALL):- Press and hold down the red button, after 2 seconds the highest part (thousands) of the current distance will be displayed. Press and hold down the red button again, after 2 seconds the lower part (units) of the current distance will be displayed (indicated by a decimal point to the left of the 3 digits). The distance will be in miles or KM according to the current readout selected. To return to menu at any point momentarily press the red button and you will return to the menu.

tr (SET TRIGGER POINTS):- Use this routine to enter the number of magnets (normally 1) that are to pass the speed sensor for one revolution of the wheel (or shaft). Press and hold down the red button, after 2 seconds the display changes to "t" and a two digit number, indicating the current number of trigger points the instrument is set to. To change the number, press the red button momentarily to increment it one at a time, or press and hold, and the display will count up quickly. When the display reaches **40** it will scroll back round to **01** .To exit the routine, release the button for more than 4 seconds and it will return to the menu, or switch off the instrument.

CAL (SET CALIBRATION of tyre circumference):- This routine is used to enter the rolling circumference of the tyre being used.

Since the whole accuracy of the speedo hinges in the accuracy of this data it is important to learn how to use it.

It can also be used to "Trim" the speedo to take into account external errors and to cater for differential ratio's when measuring from prop shafts.

Alternatively use the Auto calibration system described further on could be used. PLEASE NOTE: If the speedo is not calibrated and the sensor not set correctly, the speedo may record incorrect distance on the odometer. Correct operation is important since the odometer cannot be reset.

1) General calibration procedure:- Measure the exact circumference of the tyre at its centre. This circumference is now entered in two parts, set meters and set millimeters.

Press and hold down the red button, after 2 seconds the current circumference will be displayed in meters. To change the number, press the red button momentarily to increment it 0.1 at a time, or press and hold and the display will count up quickly. When the display reaches **4.0** it will scroll back round to **0.1**. When this has been set correctly, release the button. After 4 seconds the decimal point will shift to the left and display the remaining millimetres of circumference.

To change the number, press the red button momentarily to increment it one at a time, or press and hold and the display will count up quickly. When the display reaches **.999** it will roll over to **.000** and the meters will increase by **1**. To exit the routine, release the button for more than 4 seconds and it will return to the menu, or switch off the instrument.

2) Special calibration:- If you require to trigger from a different sensor with for example 10 pulses per rev, then set the trigger points number to **10** in the SET TRIGGER POINTS menu.

If the sensor is running at wheel RPM then simply enter the tyre circumference as described above. However if the sensor is driven from a gearbox output (EG before the differential) then using a calculator, divide the circumference of the tyre by the ratio of the differential (or whatever the drive ratio between the sensor and the wheel is due to gears, chains etc), and enter this value as the circumference (See SET CALIBRATION as described at the beginning of this section).

If you require to trim the accuracy of the speedo because for example the differential ratio is not accurately known, and you have determined that the speedo is reading say 2% high, then using a calculator, subtract 2% off the currently stored circumference value and enter this new figure as the circumference value (See SET CALIBRATION as described at the beginning of this section). The speedo will then read 2% lower than previously.

rEA (SET READOUT):- Use this option to change the readout to MPH, KMH or RPM. Press and hold down the red button, after 2 seconds the display changes to the desired option, as indicated by "KPH" or "MPH" symbols on the bottom right of the LCD display. When neither symbols are displayed, the LCD is displaying engine RPM.

ton = trip mileometer **on**, or **t--** = trip mileometer off.

Use this to set the function of the red button. When **t--** is selected, the red button functions as peak recall for speed and rpm. When **ton** is selected, the red button functions as trip mileometer recall (there is a **REC** symbol shown in the display while the button is pressed). Pressing the button down in trip mileometer mode for more than 5 seconds zeroes the trip mileage. Peak recall for rpm continues to work in either mode. Press and hold down the red button, after 2 seconds the display changes to the desired option.

All versions:-

Eng (ENGINEERING) This routine is for engineering access only and is code locked.

rEt (RETURN):- Use this option to exit the menu system and restart the instrument for normal operation. Press and hold down the red button, after 2 seconds the display will go blank, when you release the button, the instrument will restart.

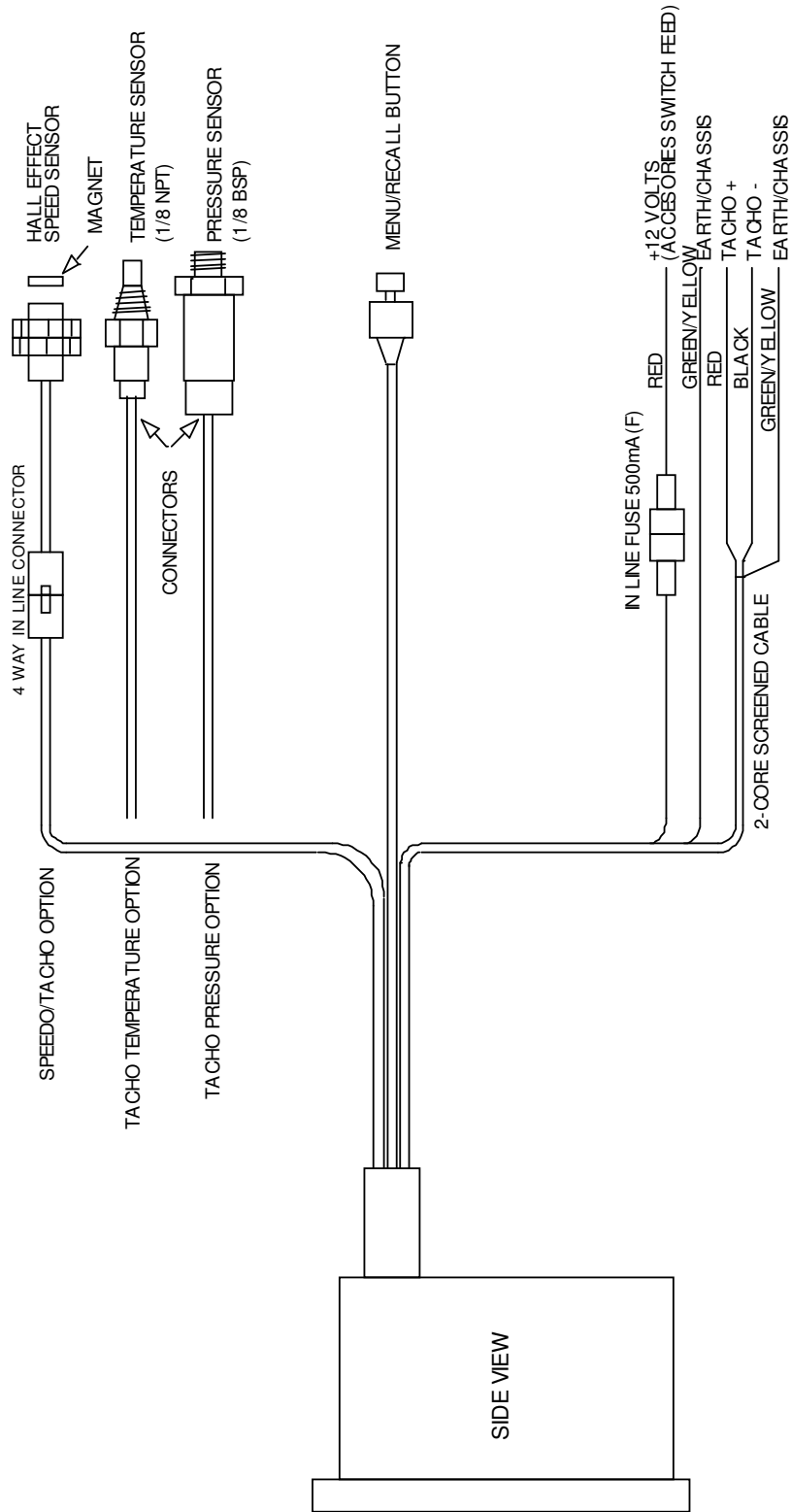

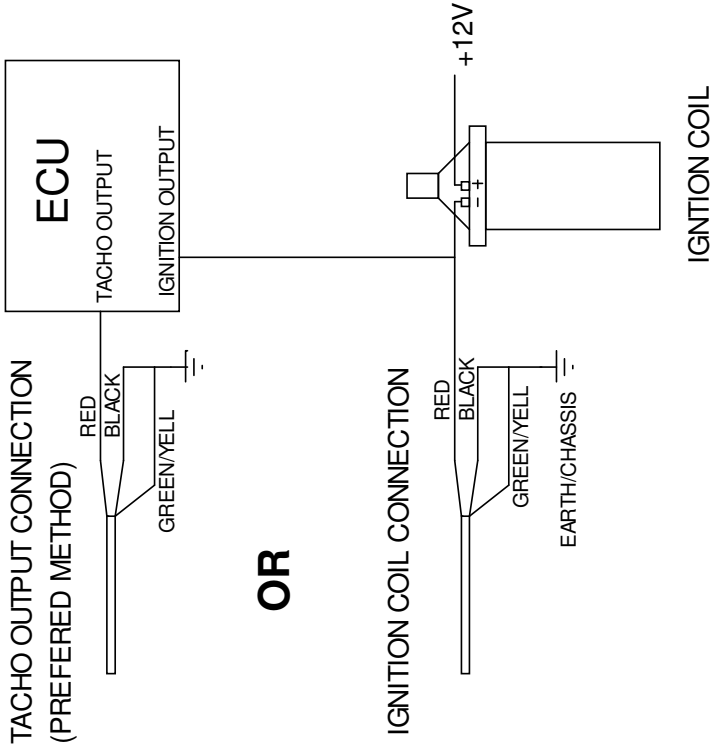
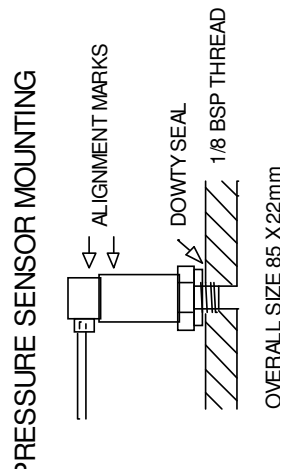
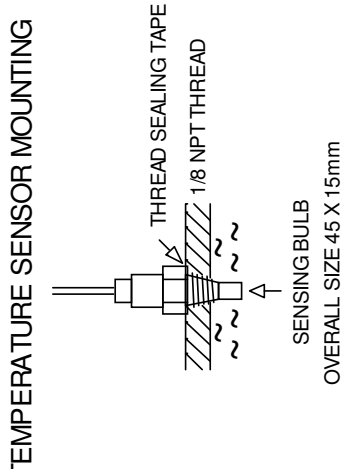

SPEEDO SENSOR INSTALLATION GUIDE

TYPICAL CAR INSTALLATION

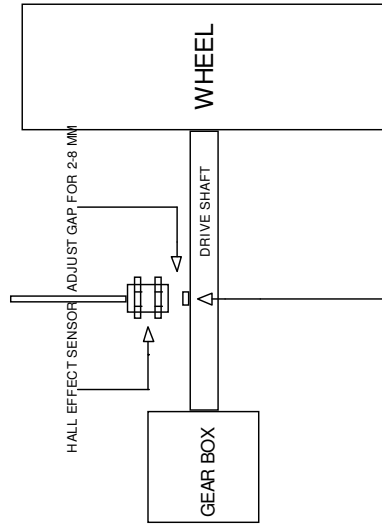

TYPICAL MOTORCYCLE INSTALLATION

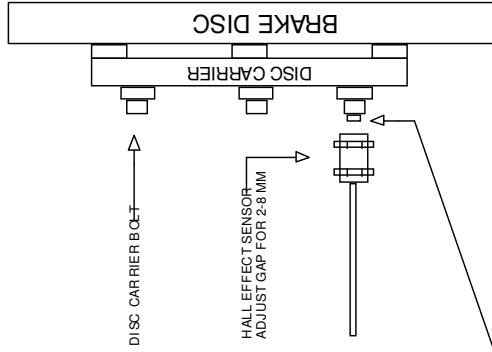

PLEASE NOTE THAT ONLY ONE MAGNET IS NOW NEEDED AND ONE IS SUPPLIED

A SUITABLE BRACKET WILL NEED TO BE MADE FOR MOUNTING THE HALL EFFECT SENSOR. THIS SHOULD BE MOUNTED ON A NON MOVING MEMBER.

DISC MAGNET
GLUE WITH NORTH POLE
FACING DOWN* ON THE DRIVESHAFT
USE EPOXY GLUE TO FIX
EG ARALDITE OR PERMABOND.
* MARKED BY DIMPLE OR RED PAINT

SPA TACHO AND COMBINED UNIT MANUAL

10 WAY PLUG

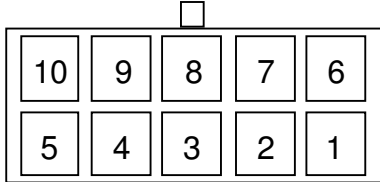

PIN NUMBER	FUNCTION	NOTE
5	GROUND (0V)	
4	+12 VOLTS BATTERY	1
1	TACHO+ (STANDARD)	
6	TACHO-	
7	TACHO+ (EXTRA HIGH VOLT)	2
2	SWITCH (GROUND)	
3	SWITCH (SIGNAL)	3
9	+5 VOLT OUT	4
10	SPEED SENSOR SIGNAL	5
8	SPEED SENSOR GROUND	

4 WAY PLUG

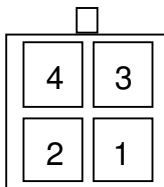

PIN NUMBER	FUNCTION	
1	+12 VOLTS BATTERY	6
2	EXTERNAL SHIFT LIGHT 1	7
4	EXTERNAL SHIFT LIGHT 2	7
3	EXTERNAL SHIFT LIGHT 3	7

- NOTE 1) 28V MAXIMUM SUPPLY
- NOTE 2) MAGNETO PIN*, MAGNETO LOOM NEEDED
- NOTE 3) NORMALLY OPEN SWITCH
- NOTE 4) CUSTOM 12V OUTPUT AVAILABLE
- NOTE 5) 5V SIGNAL WITH 10K PULL UP
- NOTE 6) 500mA MAX LOAD
- NOTE 7) 100mA MAX LOAD

* ALSO AVAILABLE AS A CUSTOM LIGHTS ON PIN

INSTALLATION, DO'S & DON'TS :-

DO'S

DO ensure that the front of the instrument and the exposed plug is protected if it is likely to get any water spray on it.

DO ensure that the speedo cable is not run next to the tacho cable or any power cable, try to run it next to the chassis.

DONT'S

DO NOT allow cables to run through sharp edged apertures without protection.

DO NOT fix the cables next to or onto any surface likely to exceed 80 degrees Centigrade.

SPEEDO SENSOR INSTALLATION, DO'S & DON'TS :-

DO'S

DO ensure that the sensor is aligned with the end of the magnet when the suspension is under normal load (not jacked up).

APPENDIX

TACHO IGNITION CONNECTION

Please use a tacho output of the management, ECU or ignition box if this available. Nearly all modern vehicles have tacho outputs, and this may be the only option on some ignition systems. They do vary in there operation however. Some do not like being loaded down to earth (EG Nissan Micra), in this case you need to connect the red wire to +12v batt, and the black wire to tacho output. If there is no tacho output available, you may be able to connect the inductive pickup output from the distributor, if the system has one.

If you do not have a tacho output, then please try the suggestions below.

The tacho ignition coil input (see schematic) is fully protected. It will easily take short CDI type pulses up to 500V (but not magneto pulses, see below) and is not damaged by reverse polarity. Try connecting black to chassis, and red to the ignition pulse side of the coil. If this does not work well, or operation is slightly erratic, please experiment with different connections. IE reverse the polarity of the connections to the coil, and/or try one connection to chassis, and the other to the coil feed. You cannot damage the tachometer by doing this. But do not make any kind of connection to the HT leads or spark plugs, this voltage is highly destructive and will likely stop the engine firing properly.

PLEASE NOTE:- Do not connect the 'Tacho+ (Standard)' input to a magneto driven coil (EG Motoplat ignition as used on KTM engines). This will overload and damage the tacho input. Please ask SPA for a magneto option loom.

EXTERNAL SHIFT LAMPS

If you wish to drive external shift lamps in addition to the internal ones, you can either use the SPA 3-stage led box optional extra, or if you wish you can use discrete leds. Leds must be of the 12v type and take no more than 100mA. If you need brighter lamps, you may drive a relay, but this must not take more than 100mA coil current, and MUST be fitted with a protection diode (EG 1N4001) across the relay coil

SPECIFICATIONS:-

INPUT VOLTAGE 8.0-26 VOLTS (working)
 CONSUMPTION 150 mA(max) @ 12 VOLTS
 FUSE 20mm glass 500mA Fast(F).

TACHO ACCURACY:-	0.05%
SPEEDO ACCURACY:-	0.05% TYPICAL
ACCELERATION TIMER	0.1 SEC
STANDING QUARTER TIMER	0.1 SEC
DATA STORAGE:-	EEPROM
WEIGHT:-	400g INCLUDING CABLES ETC
SIZE:-	90mm x 41mm DEEP
CUT OUT FOR MOUNTING	80mm
SPEEDO SENSOR FIXING DIA:-	10mm

CABLE LENGTHS:- IGNITION LEAD	120"
WHEEL SPEED SENSOR	120"
POWER SUPPLY	12"
OPTIONAL EXTERNAL SHIFT LAMP(S)	40"

ABSOLUTE MAXIMUM RATINGS:-	
INPUT VOLTAGE	28 VOLTS
ENGINE SPEED	39,990 RPM
SPEED	999 MPH/KMH
ODOMETER	999,999 KM/MILES
INSTRUMENT TEMPERATURE	0 - 50 °C